

Targeted Constituents

?? Significant Benefit		?? Partial Benefit		?? Low or Unknown Benefit	
?? Sediment	?? Heavy Metals	?? Floatable Materials		?? Oxygen Demanding Substances	
?? Nutrients	?? Toxic Materials	?? Oil & Grease	?? Bacteria & Viruses	?? Construction Wastes	

Implementation Requirements

?? High		?? Medium		?? Low	
?? Capital Costs	?? O & M Costs	?? Maintenance		?? Training	

Description

This stormwater treatment BMP addresses a variety of water quality enhancing inlets, consisting of modified catch basins and media filtration inlets, with oil/water separators being specifically addressed in F02.

Modified catch basins contain an oversized sump, and also some type of inflow and outflow control to remove coarse sediments and floatable materials. Modified catch basins are effective as a pretreatment measure for other BMPs, but are not sufficient to provide stormwater treatment as a standalone measure.

Catch basin inserts are a relatively new type of technology in the realm of stormwater quality best management practices (BMP's). This technology involves the placement of devices that contain a filtering media (a sorbent) just under the inlet of a storm drain. Runoff flows into the inlet and through the filter where the targeted contaminants are removed. They can be an effective means of petroleum hydrocarbon control, thereby reducing non-point source pollution.

Media filtration inlets use materials such as sand, peat, screens, patented sorbent paper media, or cloth to filter stormwater runoff. Sand filtration inlets can be constructed in a variety of layouts using precast vaults, paved trenches, or in earthen or concrete basins. Media filtration systems are available commercially with a wide range of materials and methods for easy installation and operation. Media filtration inlets will create a partial reduction in most pollutants only if they are inspected, cleaned and maintained on a regular basis. A layer of organic material (such as peat moss) or potentially some types of clay can increase the removal of metallic ions and organic pollutants from stormwater runoff.

Selection Criteria

There are several models or designs of catch basin inserts on the market, which can meet site specific conditions. Catch basin inserts are not designed to be a standalone BMP but rather to be used as a first flush treatment practice prior to a storm drain network, detention/retention facility, infiltration practice, or some other form of water quantity control measure. They are usually applied in highly urbanized areas, where space is not available for more effective BMPs.

- ? ? Modified catch basins (with enhanced capability to capture coarse sediments and floating debris) and media filtration inlets may be used on commercial and industrial properties that have parking lots and vehicle traffic. This type of land use is likely to receive salts and sands for removing ice and snow, trash from vehicles, leaking oil and grease, and leaves and dirt from landscaping.
- ? ? Water quality enhancing inlets may be used for most impervious properties with parking lots and vehicle traffic. They are also highly recommended for commercial and industrial sites that generate fine particles, sediment, tailings, sawdust or other pollutants for which a media filtration inlet would be effective.
- ? ? Media filters are primarily used for water quality control, although they do provide detention and slow release of treated water. Additional calculations will be required to check for proper detention.

Design and Sizing Considerations

The various types of water quality inlets should be selected according to targeted constituents, site area constraints, cost and frequency of maintenance, and inspection requirements. Media filtration inlets can essentially be designed to filter any particle size and particle type imaginable at low to moderate flow rates. Many filtration systems are readily available from commercial vendors in a variety of sizes, layouts, and targeted pollutants. Water quality inlets can be designed for new property uses or can often be retrofitted onto existing stormwater drainage systems.

Catch basin inserts are not capable of handling large amounts of runoff volume, but are sufficient in providing water quality improvement in low density areas. Catch basin inserts generally perform best when they serve parking lots less than 1 acre in size or urban roadways. In most situations, they must be used in conjunction with other water quantity BMPs to meet stormwater management criteria.

A very important decision to be evaluated is the ability to bypass or convey large storm events that have the potential to damage the BMP system or resuspend collected pollutants. Figure F-01-1 shows one method for allowing high flow stormwater to bypass the BMP system; there are many other types of flow-splitting structures that allow the BMP system to function “off-line” rather than “on-line”. The minimum requirement for water quality inlets (including media filtration inlets) is to treat the first flush volume.

Due to the precast nature of this BMP, the engineer or planner who is responsible for the installation and operation of the catch basin insert needs only to be concerned with determining the site-specific characteristics. The volume of the water that is to be treated must first be determined (i.e., first flush, entire 2-yr storm, etc.). Once the volume is found, a hydrologic analysis must be determined the actual volume of runoff that the insert will treat. The dimensions of the catch basin that is collecting the runoff must be determined in order for the manufacturer to correctly fabricate the BMP and assure that the insert will not be the limiting factor when it comes to passing the design flow. The design engineer also needs to estimate the types and amounts of pollutants the catch basin will trap.

Some advantages of water quality inlets are:

- ~~•~~ Does not require a supply of water (such as wet detention basins or wetlands).

- ~~Can~~ Can be placed underground as part of the storm drainage system.
- ~~Suitable~~ Suitable for smaller catchments including parking lots and roadways.
- ~~Many~~ Many types of filters are suitable for larger drainage areas up to 5 or 10 acres.
- ~~Sand or~~ Sand or cartridged media filters may be particularly suitable for industrial sites because they can be located underground and industrial facilities generally have the resources to routinely inspect and maintain the systems.
- ~~There~~ There can be marked reduction of hydrocarbon loadings from areas with high traffic/parking volumes.
- ~~The~~ The underground placement is not generally noticeable and therefore does not make this BMP aesthetically unpleasant.
- ~~Their~~ Their underground placement does require the utilization of valuable space in highly urban areas.
- ~~This~~ This BMP can also be retrofit into most existing catch basins without additional construction.

This BMP fact sheet discusses the general uses of modified catchbasins and media filtration inlets. The practices presented in F02, Oil/Water Separator, should also be reviewed when oil and grease are likely to be present in stormwater runoff.

A typical modified catch basin, as shown in Figure F01-2, will capture coarse sediments and floating debris. A modified catch basin could have many possible variations that will essentially perform the same function. The modified catch basin must have removable elements to allow inspection and cleaning of all pipes.

A sand filter is probably the most common type of media filtration system used. Figure F-01-3 shows a surface sand filter system, which is easier to inspect and usually less costly than an underground sand filter system. The detail shown can be sized to handle several acres. Filter cartridges or other media may also be acceptable alternatives to using sand if maintenance and operation considerations are addressed.

Figure F-01-4 shows a manufactured BMP media filtration system called StormFilter, manufactured by Stormwater Management Inc. It is similar to the sand filter vault (shown in Figure F01-6), except it uses media cartridges instead of sand. The internal valving, hardware and cartridges are installed into a precast concrete vault. Media cartridges are especially useful for industrial sites where specific types of particles can be targeted. Media cartridges can be designed to target specific pollutants such as sediments, oil and grease, organics, heavy metals, and soluble nutrients. StormFilter requires 2.3 feet of head differential across the unit to work properly. SMI also makes a high-flow bypass system called StormGate. Contact manufacturer for design and installation details and pricing at

<http://www.stormwaterinc.com>

Two different types of underground sand filter layouts are also included as details. Underground filtration systems are more difficult to inspect and maintain. On the

other hand, underground filtration systems are protected from weather and other hazards, and do not take up valuable real estate. Underground systems may exhibit odor problems during the summer because of a lack of bacterial degradation of accumulated organic matter and a lack of aeration within the wet pool.

The Delaware sand filter (Figure F01-5) is suitable for overland sheet flow from paved areas such as commercial properties or industrial sites. Originally designed by Mr. Earl Shaver for the state of Delaware, it has two parallel concrete trenches or vaults. The first concrete trench serves as a sedimentation basin and storage facility to evenly distribute water across the sand filter in the second concrete trench. A clearwell is located at the end, with room for an overflow weir and underdrain system to outlet.

The underground sand filter (Figure F01-6) handles concentrated flow after it has already been collected within a storm drainage system. The front end of the system helps to trap sediment and floatable materials prior to entering the sand filter. The underground sand filter should contain an overflow bypass within the vault, or alternatively a flow-splitter prior to the system.

Figure F-01-7 shows a grate inlet filter insert that uses trays to improve stormwater quality. Figure F-01-8 shows a grate inlet filter insert that uses sorbent material to capture oil and grease. Some special types of sorbent material are durable and strong enough to remain in a filter tray for months, with exceptional capacity for absorbing oils and grease. Figure F-01-9 shows two types of catch basin modifications that will produce clog-resistant media filtration inlets. In general, catch basin filter inserts should only be used wherever maintenance staff is available to check the filters frequently and where local flooding will not occur if the filters should clog. Some companies manufacture the insert frame (stainless steel or fiberglass), which can generally be fabricated in any size to match an existing or proposed inlet. The filter medium typically consists of a blown polypropylene filter with a dacron outer scrim, which is designed to handle oils, grease, PCBs and sediments. Contact manufacturers for design and installation details and pricing at:

<http://www.remedialsolutions.com>

<http://www.suntreotech.com>

Two media filtration inlet manufacturers are included in this BMP. Manufactured systems should be selected on the basis of good design, suitability for desired pollution control goals, durability of materials, ease of installation, and reliability. The products listed here are not intended to be a specific endorsement or recommendation. It is incumbent upon the property owner and developer to carefully investigate the suitability and overall trustworthiness of each manufacturer and/or subcontractor.

Media filtration systems are most effective under smaller flow volumes such as the first flush volume. Although media filtration systems must have a buildup of water above the media in order to function, they are generally not effective under conditions of heavy rainfall or floods. Furthermore, some systems can be damaged or the pollutants could be resuspended if operating under high flow or flooding conditions. To prevent overloading filtration systems, there should be a mechanism to bypass or divert large flows. Commercially available systems may have a high flow bypass built into the equipment. Other systems may require construction of an overflow bypass weir or other structure.

There are no design requirements for a modified catch basin, other than the minimum

dimensions shown in Figure F01-2. Extra attention may be required for multiple inlet pipes or special flow conditions, possibly requiring a larger size for a catch basin.

When using commercial products such as water quality inlets, the manufacturer's recommendations should be considered in the product sizing and applicability. Verify that adequate stormwater treatment is provided and that high flow bypass methods do not hinder the system from adequately treating the first flush volume.

A major drawback for a media filtration inlet is the need for elevation differences in the storm drainage system. A media filtration typically needs at least 3 feet of head loss available across the system, in order to accommodate live pool storage and sand filter thickness.

The liner or concrete shell of the sand filter should be placed at least 2 to 4 feet above the seasonally high ground water table or bedrock. This minimizes the infiltration of groundwater into the filter.

Filtration Volume:

The volume of the live pool for a sand filtration or other media filtration system shall usually be the first flush volume, which is intended to be slowly released through the filtration device after being treated. The live pool may include any storage capacity of incoming pipes and catch basins that is clearly not part of the dead pool volume. The dead pool volume is the portion of the filtration system which always has water (such as underground sand filters). Some examples of live pool volumes are shown in Figures F-01-3, F-01-5, and F-01-6. Larger filtration volumes are typically much easier to accommodate within an open system such as the surface sand filter.

Filtration Surface Area:

Many equations have been proposed to determine the surface area of a sand filter, including that used by the city of Austin TX and throughout the state of Virginia (Austin (city of), Texas, 1989 and Virginia Department of Conservation and Recreation, 1999). Proper gradation of sand filter must be achieved. Additional design criteria for the surface sand filter (Figure F01-3) include:

~~2.2~~ Size the control orifice or perforated riser pipe to allow for a 24 hour drawdown time, in conjunction with allowable sand filtration loading rate.

~~2.3~~ Provide an energy dissipater prior to the sedimentation basin to reduce turbulence. Consider using some type of flow-splitter immediately upstream of a surface sand filter.

~~2.4~~ Typical length-to-width ratio of the sedimentation basin should be at least 3:1 (L:W) to prevent possible shortcutting. Allow for a minimum freeboard of 6". Provide easy vehicle access to basin for maintenance and cleaning.

Additional design criteria for the Delaware sand filter (Figure F-01-5) and the underground sand filter (Figure F01-6) include:

~~2.5~~ The live pool volume typically is the most stringent requirement to meet. An adjacent vault may be needed to provide additional live pool volume. Ensure that stormwater runoff flow entering the sand filter is distributed evenly.

~~2.1~~ Structural design should be performed by a professional engineer in areas where traffic loading is a concern. Otherwise, prevent vehicles from driving onto any type of underground structure while ensuring nearby access.

~~2.2~~ Provide baffled walls to reduce entrance velocities. The front portion of the structure should contain a dead storage pool to retain floatable materials and sediment. For ease of inspection and maintenance, limit the depth of the dead pool volume to less than 4 feet.

~~2.3~~ Provide adequate access for inspection, cleaning and maintenance activities for each chamber. Removable access covers are recommended for chambers that do not have adequate standing room. Provide steps or rungs as needed.

~~2.4~~ Use geotextile fabric on top of the sand layer to prevent displacement. Use geotextile fabric beneath the sand layer to prevent loss of material through the gravel underdrain layer. A typical underdrain pipe is 4" diameter schedule 40 PVC pipe, with 3/8" perforations around the pipe diameter at 6" spacing. Place underdrains at 5' lateral spacing with a 1% to 2% positive grade.

A pretreatment sedimentation basin is essential to avoid rapid clogging of the filter medium. Since peat seems to be very effective at removing dissolved contaminants such as heavy metals, there has been research into using peat/sand mixtures (Galli, 1990 and Tomasak, Johnson, and Mulloy, 1987) which are subject to clogging problems. Research has also indicated that compost made from leaves is very effective at removing dissolved phosphorus and metals, and oil and grease (Stewart, 1989). Field research at Austin, Texas in 1990 indicates that the surface sand filter has a removal efficiency of total suspended solids that is similar to wet and dry detention basins: about 70 to 90%. Removal rates for heavy metals, oil and grease vary from 20% to 80%, depending on the application.

Consult references for additional design and maintenance criteria. Inspection and maintenance frequency will also greatly affect pollutant removal rates.

Catch Basin Inserts

Catch basin inserts are ideal for industrial sites as they fit into existing catch basins, and therefore may avoid the need for an "end-of-pipe" facility. Typical catch basin inserts are shown in Figures F-01-7 and F-01-8, consisting of a series of trays or sorbent rolls/tubes. The top trays are designed to capture coarse sediments, and lower trays may capture finer sediments or specific pollutants. Inserts made from fiberglass insulation materials can achieve up to 90% removal for heavy metals, oils and grease (McPherson, 1992). Since catch basin inserts require frequent inspection and maintenance, they should only be used where a full-time maintenance person is located on the site (typically at large commercial or industrial facilities). A typical insert design may have a high-flow bypass and should be hydraulically designed to allow stormwater runoff into the drain system without danger of local flooding. A list of insert manufacturers can be found in Table F-01-1.

**Construction/
Inspection
Considerations**

Devices should be installed in accordance with manufacturer specifications.

Catch basin inserts will not function properly if clogged with sediment and debris, and therefore most of the designs are not recommended near construction areas without appropriate sediment control. There are some inserts that are designed especially for the removal of high sediment loads from construction sites.

Maintenance

~~etc~~ Inspect modified catch basins and media filtration systems on a regular basis, typically every month and after heavy rainfalls. Record observations in an inspection log and take pictures as necessary to document conditions. Make immediate repairs as needed. Clean or replace filtration media as needed to prevent clogging.

~~etc~~ Perform cleanout on a regular basis using confined space procedures and equipment as required by OSHA regulations, such as nonsparking electrical equipment, oxygen meter, flammable gas meter, etc. Remove trash, debris, sediments or clogged media as needed, and then dispose of them properly. Sediments or clogged media may contain heavy metals or other toxic substances and should be handled as hazardous waste. Removal of sediment or clogged media depends on the accumulation rate, available storage, watershed size, nearby construction, industrial or commercial activities upstream, etc. Sediment or clogged media should be tested for identification of pollutants prior to disposal.

~~etc~~ Some sediment may contain contaminants for which the Tennessee Department of Environment and Conservation (TDEC) requires special disposal procedures. Consult TDEC - Division of Water Pollution Control if uncertain about what the sediments contain or if it is known to contain contaminants. Generally, give special attention or sampling to sediments accumulated in industrial or manufacturing facilities, fueling centers or automotive maintenance areas, large parking areas, or other areas where pollutants are suspected to accumulate.

~~etc~~ It is generally more cost efficient to clean the filtration media. For sand filters, cleaning or replacement of the top few inches may restore the permeability rate. Failure to clean the filter surface regularly may result in the need to replace the entire media because of penetration of fines into the filter.

~~etc~~ A very important consideration is the allocation of long-term resources for inspection, maintenance and repair. Water quality enhancing inlets should only be constructed if: 1) there is a maintenance plan to regularly inspect and maintain inlets on a long-term basis, and 2) there is an agreement or fiscal guarantee that the required maintenance resources will be available throughout the operation life of the water quality inlets. Without regular inspection and maintenance, a water quality inlet will fail and generally create a worse pollution problem than having no inlet at all.

~~etc~~ Routine maintenance procedures, although frequent, are not overly time consuming relative to BMPs such as retention/detention ponds, infiltration trenches, and constructed wetlands.

~~etc~~ It is important to keep the filters clean. Any debris, sediment, grass clippings, etc. should be removed from the system and properly disposed.

Cost Considerations

Insert cartridge replacements and maintenance can be expensive, depending on specific type of system used. Table F-01-1 compares costs, applications, and removal efficiencies for several types of catch basin inserts.

As a whole, this BMP is relatively expensive, considering the limited pollutant removal capabilities under typical field conditions and the relatively frequent need for replacement.

Limitations

~~EE~~ Media filtration systems and modified catch basins will require more frequent inspection and maintenance than most other stormwater treatment BMPs. Filtration media will need to be cleaned and/or replaced frequently. There is very high potential for severe clogging or reduced pollutant removal efficiency in filtration systems, particularly if there are un~~st~~abilized soil surfaces upstream. Do not operate filtration systems until upstream erosion areas are controlled.

~~EE~~ Media filtration systems cause a large head loss that may require special consideration in the hydraulic design of the overall stormwater collection system. Systems may typically require vertical filtration through at least 18 inches of sand and 6 inches of underdrain material, for an absolute minimum head loss of 2.5 feet.

~~EE~~ There is a possibility of pulse loadings due to resuspension of pollutant from dirty filters during intense storms.

~~EE~~ It is difficult to dispose of spent filter media in methods that are environmentally sound and cost-effective.

Additional Information

Additional information can be found on the following page.

ACTIVITY: Catch Basin Inserts / Media Filter

F – 01

Type of Insert	Applications	Target Pollutants	Capital Costs	Maintenance Frequency	Filter Longevity	Oil and Grease	Heavy Metals	TSS
AquaShield	New and existing industrial, commercial, governmental, institutional, & multi-family developments	Oil & Grease, TSS, Nutrients, Heavy Metals, BOD	\$997 to \$3250	After rainfall > 0.5" in 24 hours; Prior to wet season; After treating 10x design flow capacity	~ 3 months	98%	86%	82%
BMT Storm Clenz Filter	Areas of high hydrocarbon loading, accompanied by low sediment volumes	Sediment & petroleum hydrocarbons	\$350 to \$800	3x per year; prior, during, end of wet season	3 to 4 months	Absorbs 5x its weight	No specific claims	No specific claims
Enviro-Drain	Parking lots, downtown areas, residential/commercial/industrial areas	Hydrocarbons, organics, sediment, heavy metals, nutrients, debris	\$4500	From after every major rain event to after >5 inches of rain	At least every 3 months	97%	97%	97%
Fossil Filter	Anywhere motor vehicles move, park, refuel, or are serviced	Oil & grease, gasoline, diesel fuel	\$400	At least 3x / yr; Once prior to main wet season and twice during	~ 6 months	98%	No specific claims	No specific claims
Gullywasher	Parking lots, residential & downtown streets, commercial areas	Petroleum hydrocarbons, sediment, debris	\$450 to \$700	From after every major rain event to after >5 inches of rain	At least every 3 months	No specific claims	No specific claims	No specific claims
Hydro-Cartridge	Parking lots, roadways	Sediment and petroleum hydrocarbons	\$680 to \$1160	2 weeks to 1 month	6 to 8 months	> 90%	No specific claims	> 90%
SIFT Filter	Areas of high hydrocarbon loading	Petroleum hydrocarbons	\$350 to \$700	6 months to 1 year	6 months to 1 year	99.4%	No specific claims	No specific claims
SiltSack	Construction sites & other land disturbing activities	Suspended sediment	\$70	After every major rain event	Highly variable	98%	98%	98%
Storm Watch	Areas of high hydrocarbon loading, Construction sites	Sediment & petroleum hydrocarbons	\$63 to \$125	After every major rain event	3 months to 1 year	93% *	No specific claims*	81% *
Stream Guard	Construction sites, Areas of high vehicle volume or exposure, Stadiums, Shopping malls, Downtown streets, Waterfront tourist areas	Oil & Grease, TSS, Trash & Debris	\$53 to \$89	Trash/Debris Model and Sediment Model- weekly to monthly; Oil & Grease Model - monthly	3 months to 1 year	93%	No specific claims	81%
Ultra-Urban	Areas of high hydrocarbon loading, accompanied by low levels of sediment & debris	Oil & Grease, Sediment, Debris		Every 3 months	~ 1 year	80%	No specific claims	No specific claims

* Removal data for Storm Watch based on Stream Guard, because they have basically same design

Table F-01-1
Catch Basin Insert/Filter Characteristic Comparison Matrix (Wagner, 1999)

A high-flow bypass structure may also be constructed in a rectangular structure or an open channel using diversion weirs.

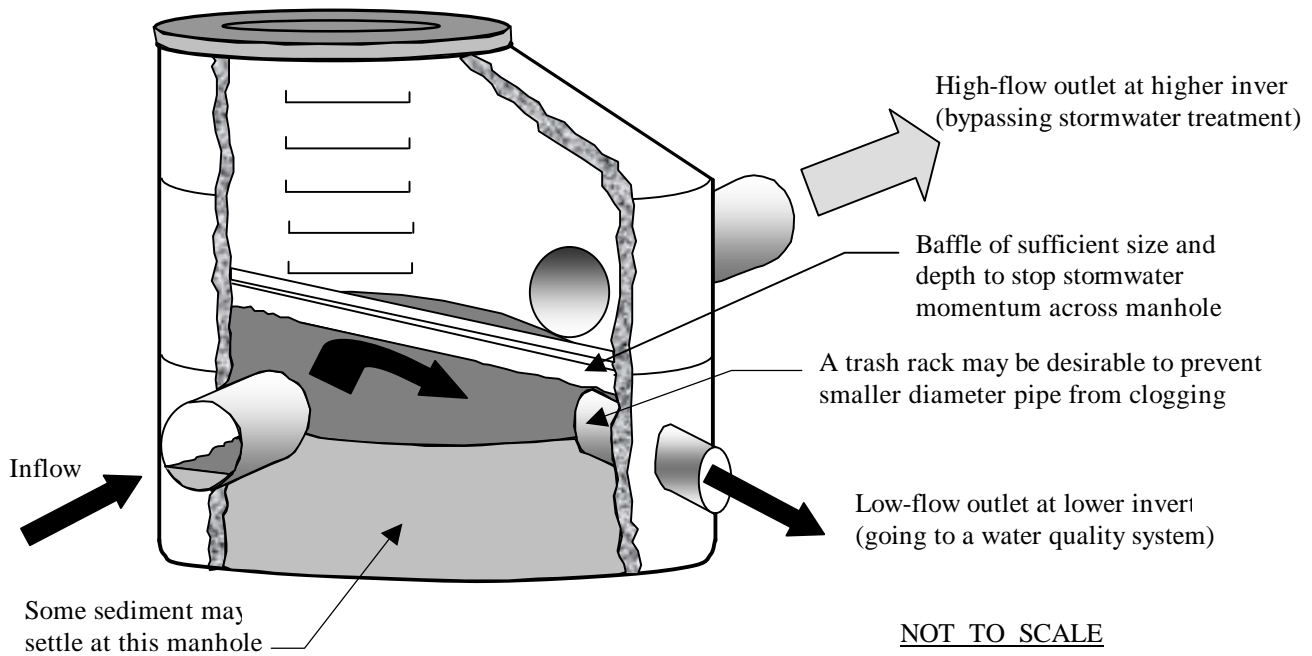

Figure F-01-1
Typical Stormwater High-Flow Bypass Manhole

Notes:

1. Securely attach pipe elbow, tee or cross to the manhole or structure to resist expected flow velocities and forces. Bolts or other removable fasteners should preferably be used. Cross braces or other supports may be necessary.
2. A modified catch basin is a good practice for areas with potential sediment loads, and as a pretreatment unit for most other stormwater treatment BMPs.

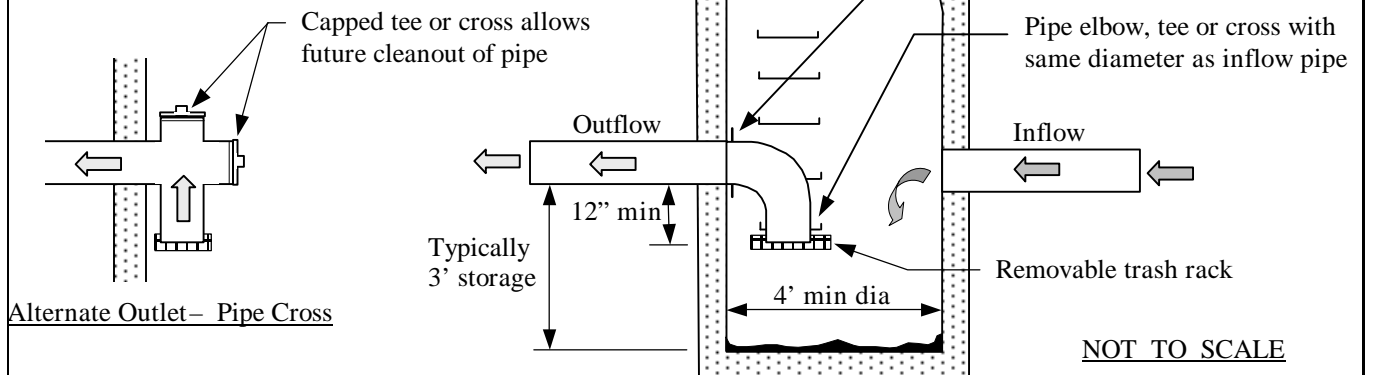
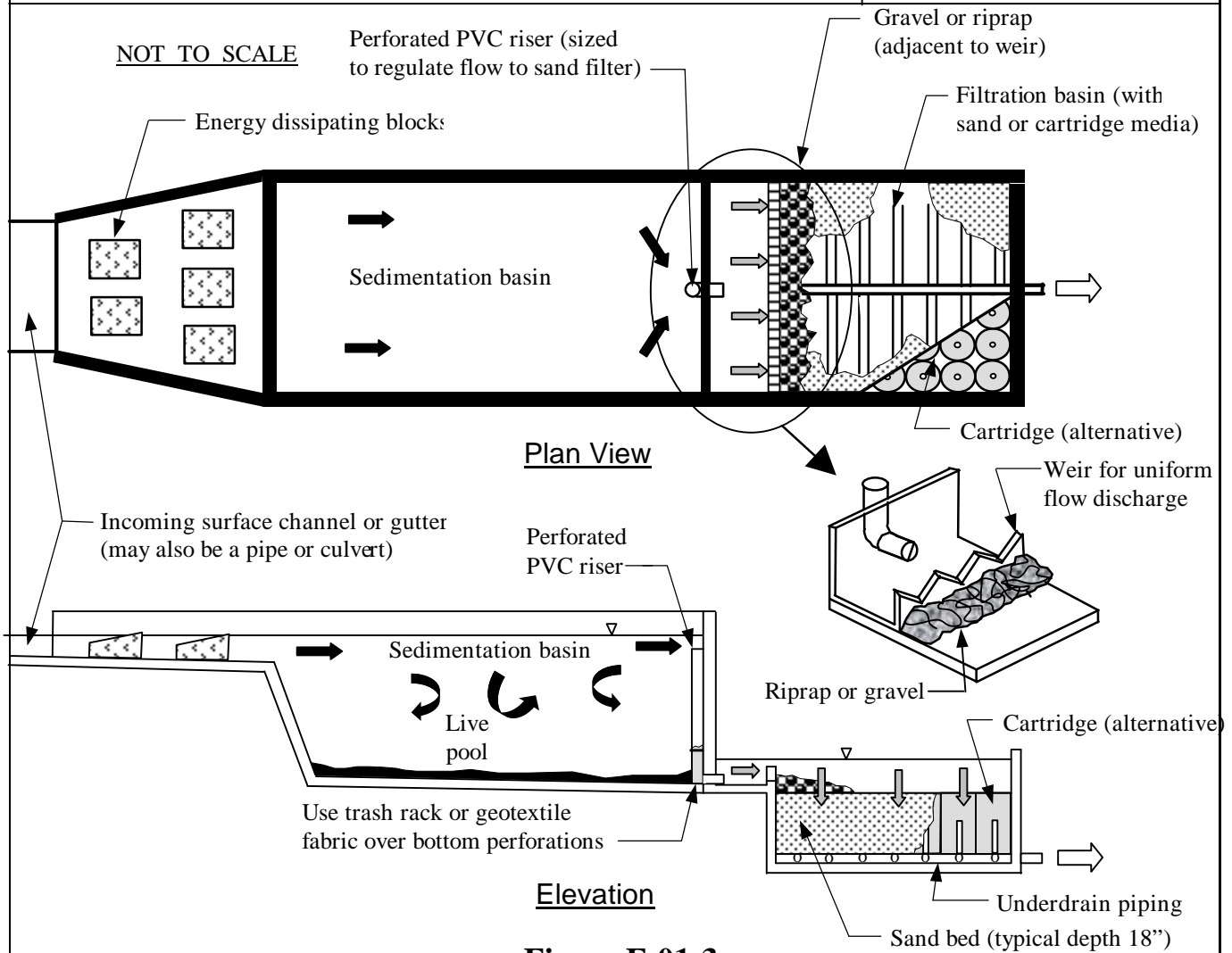
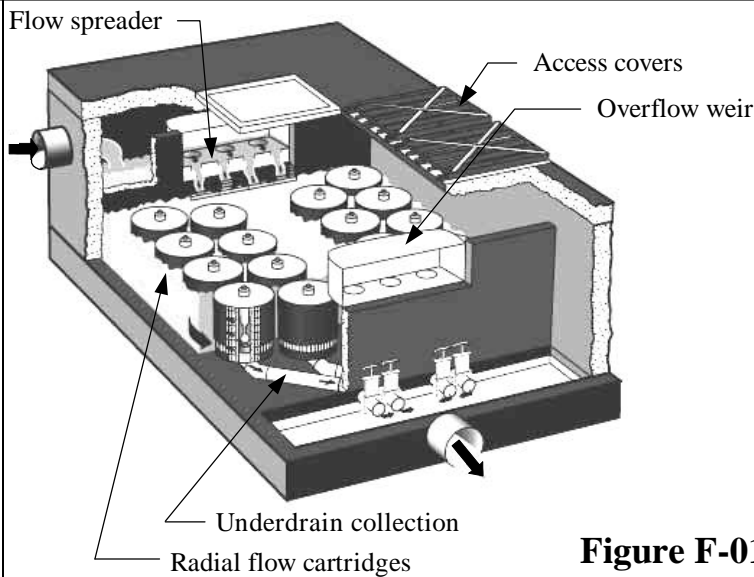

Figure F-01-2
Modified Catch Basin



**Figure F-01-3
Surface Sand Filter**



**Figure F-01-4
StormFilter (Media Cartridge)**

Notes:

1. StormFilter is manufactured by Stormwater Management Inc. located in Portland, Oregon. The end product consists of a precast vault (sized by SMI and produced by a local precast vendor) and the necessary valving and hardware. SMI also makes a high-flow bypass system called StormGate. See <http://www.stormwaterinc.com> for details.
2. Media cartridges can be designed to target specific pollutants such as sediments, oil and grease, organics, heavy metals, and soluble nutrients. The StormFilter requires 2.3 feet of head differential across unit

NOT TO SCALE

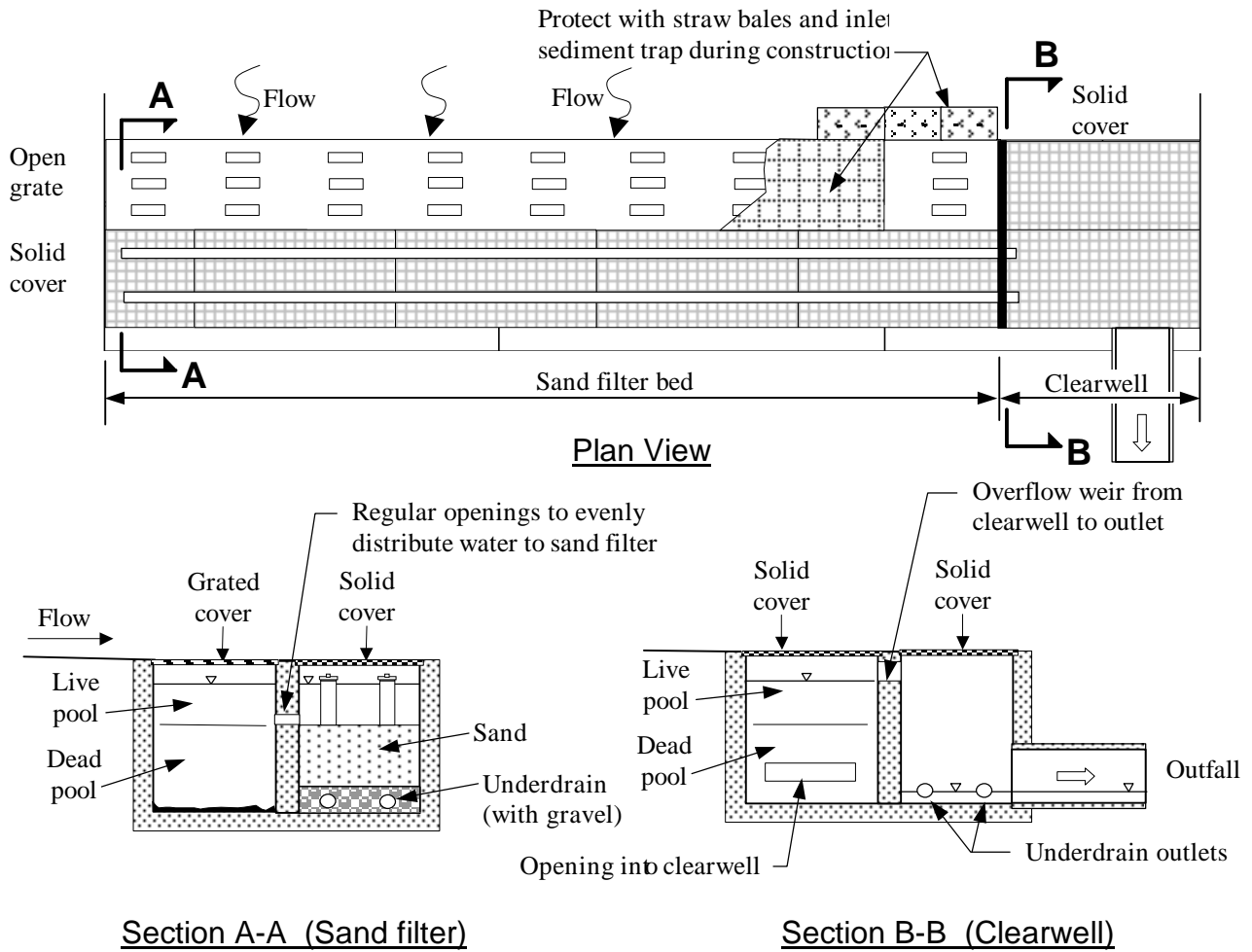

Figure F-01-5
Delaware Sand Filter

NOT TO SCALE

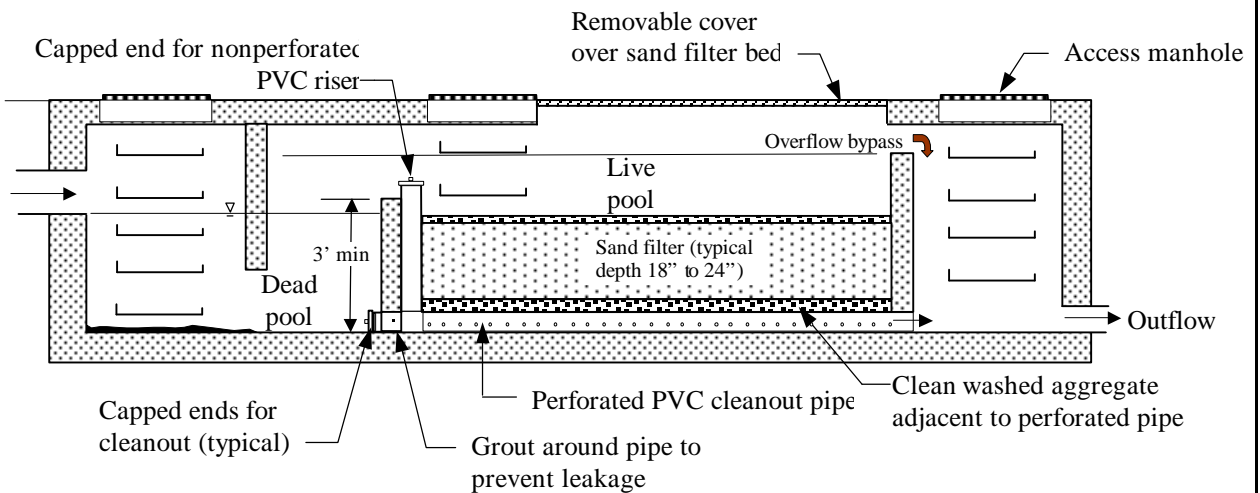
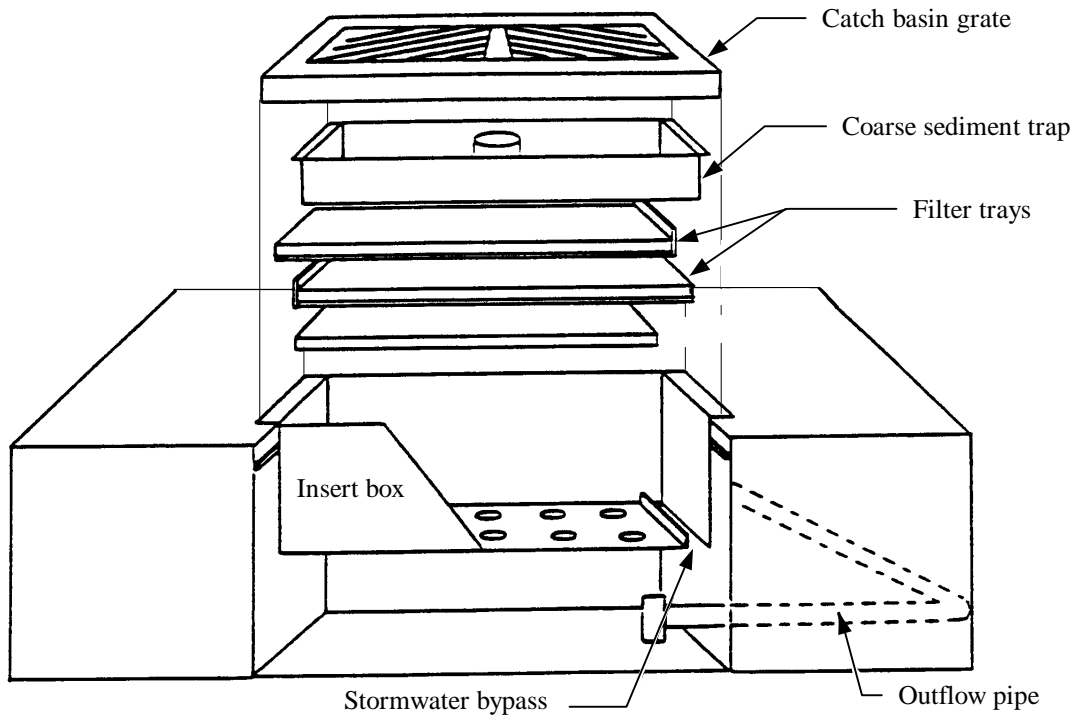

Figure F-01-6
Underground Sand Filter

NOT TO SCALE



NOT TO SCALE

Figure F-01-7
Typical Grate Inlet Filter (with Filter Trays)

Typical manufacturers of grate inlet inserts –

<http://www.remedialsolutions.com>

<http://www.suntreetech.com>

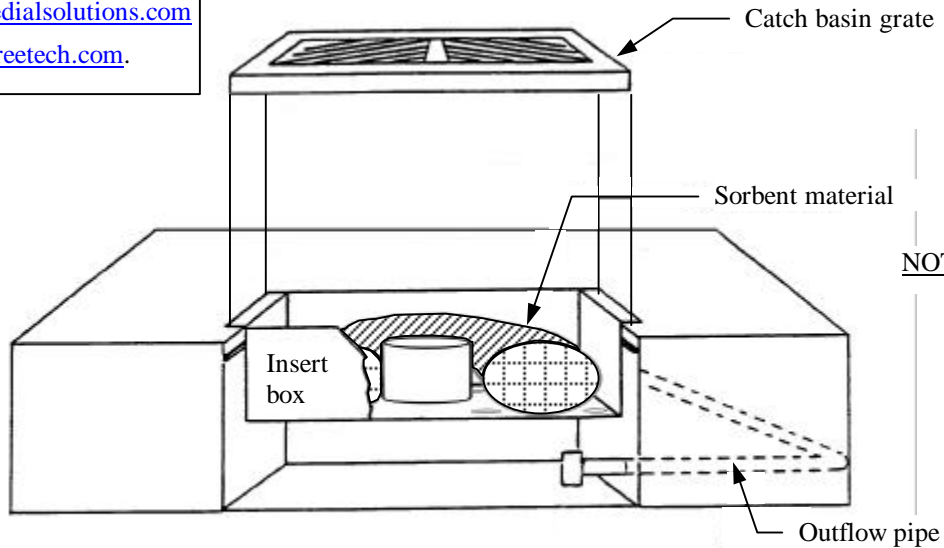

NOT TO SCALE

Figure F-01-8
Typical Grate Inlet Filter (with Sorbent Material)

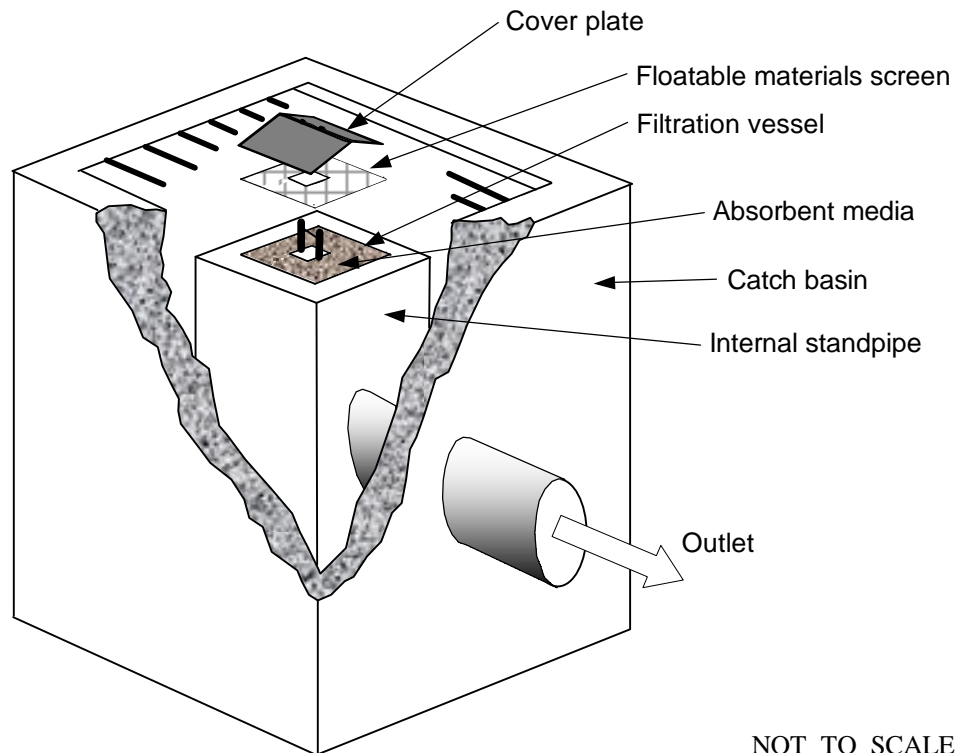

NOT TO SCALE

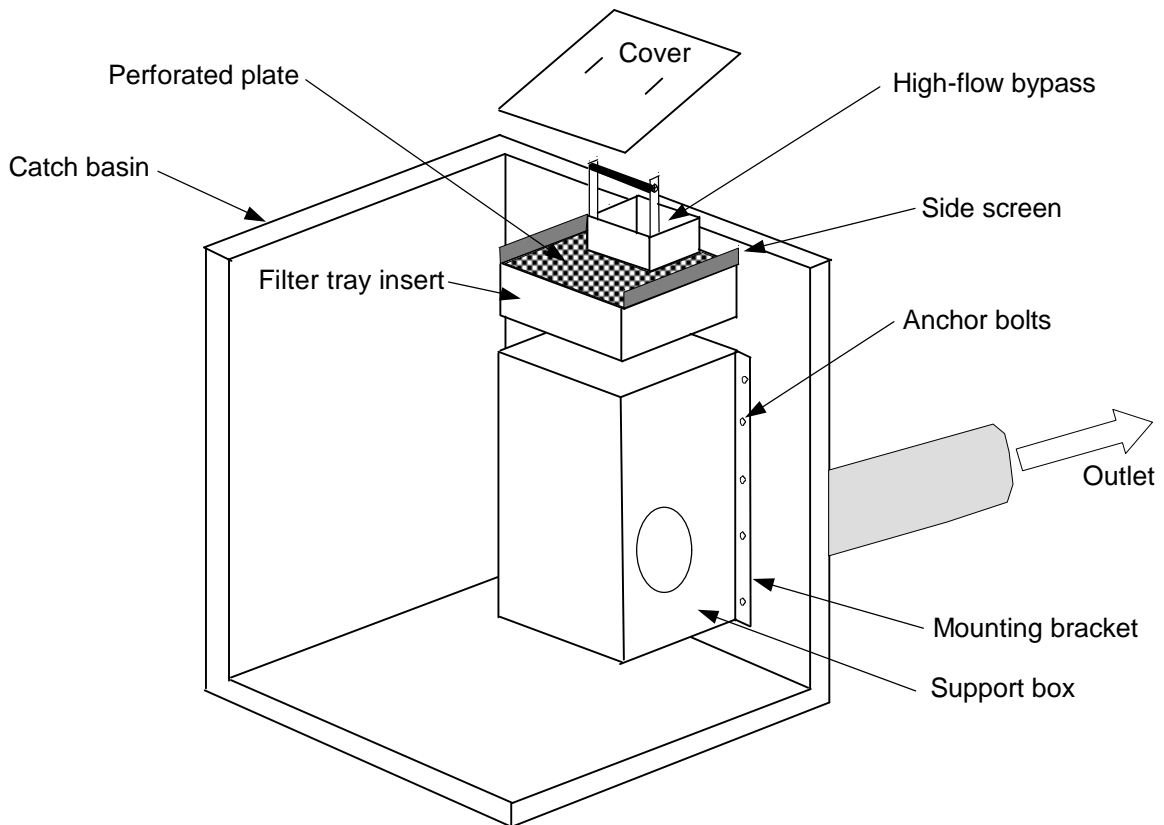

Figure F-01-9
Clog-Resistant Media Filtration Inlets

References

- AbTech Industries, Inc., Ultra-Urban™ Filter Technical Notes, Scottsdale, AZ, 1999.
- ACF Environmental, Siltsack® Information Brochure, Richmond, VA, 1999.
- Austin (city of), Texas, *Environmental Criteria Manual*, 1989.
- Austin (city of), Texas, *Removal Efficiencies of Stormwater Control Structures*, 1990.
- Camp Dresser & McKee, Larry Walker Associates, Uribe & Associates, Resources Planning Associates, *Industrial/Commercial Handbook, California Storm Water Best Management Practice Handbooks*, for the California Storm Water Quality Task Force (SWQTF), March 1993.
- Camp Dresser & McKee, Woodward-Clyde, Aguilar Engineering, Psomas & Associates, MK Centennial, *Construction Contractors Guide and Specifications, Caltrans Storm Water Quality Handbooks*, prepared for the California Department of Transportation, 1997.
- Camp Dresser & McKee, Woodward-Clyde, Aguilar Engineering, Psomas & Associates, MK Centennial, *Construction Staff Guide, Caltrans Storm Water Quality Handbooks*, prepared for the California Department of Transportation, 1997.
- Camp Dresser & McKee, Woodward-Clyde, Aguilar Engineering, Psomas & Associates, MK Centennial, *Planning and Design Staff Guide Update, Caltrans Storm Water Quality Handbooks*, prepared for the California Department of Transportation, 1997.
- Enviro-Drain Inc., product brochures, Kirkland, Washington, 1992.
- Foss Environmental, World Wide Web Page, URL Address: <http://www.fossenv.com>, 1999.
- Galli, J., *Peat-Sand Filters: A Proposed Stormwater Management Practice for Urbanized Areas*, Metropolitan Washington Council of Governments (MWCOG), Publication 91702, December 1990.
- Greb, S.R., *Evaluation of Stormceptor™ and Multi-Chamber Treatment Train as Urban Retrofit Strategies*, Wisconsin Department of Natural Resources, Madison, WI, 1998.
- KriStar Enterprises, Inc., Fossil Filter™ Engineering Binder, Cotati, CA, 1999.
- McPherson, J., *Water Quality BMPs: Catch Basin Infiltration*, presented to the APWA Stormwater Managers Committee, Tacoma, Washington, 1992.
- Metropolitan Washington Council of Governments (MWCOG), *A Current Assessment of Urban Best Management Practices: Techniques for Reducing Nonpoint Source Pollution in the Coastal Zone*, Publication #92705, March 1992.
- Remedial Solutions, Inc., *AquaShield™ Filtration Systems Design, Operation, and Technical Manual*, Chattanooga, TN, July 1998.

Schueler, T.R., P.A. Crumble, and M.A. Hearaty, “Current Assessment of Urban Best Management Practices; Techniques for Reducing Non-point Source Pollution in Coastal Zones,” Metropolitan Washington Council of Governments, Washington, D.C., December, 1991.

Shaver, E, *Sand Filter Design for Water Quality Treatment*, Delaware Department of Natural Resources, 1991.

Stewart, W., *Evaluation and Full-Scale Testing of a Compost Biofilter for Stormwater Runoff Treatment*, presented at the Annual Conference of the Pacific Northwest Pollution Control Association, 1989.

Stormceptor Corporation, Stormceptor™ Product Brochure, Rockville, MD, 1999.

Stormwater Management, Inc., Stormfilter™ Product Brochure, Portland, OR, 1999.

Stormwater Technologies Trade Show, Innovative Stormwater Treatment Products and Services, Providence, RI, May 25, 1999.

Tennessee Department of Transportation (TDOT), *Standard Specifications for Road and Bridge Construction*, March 1995.

Tomasak, M.D., G.E. Johnson, and P.J. Mulloy, *Operational Problems with a Soil Filtration System for Treating Stormwater*, Minnesota Pollution Control Agency, 1987.

Truong, H.V., *The Sand Filter Quality Structure*, District of Columbia Government, 1989.

Tschantz, B., Wagner, C., *Evaluation of Stormwater Quality Performance of Catch Basin/Filter Inserts*, proceedings paper and presentation to Tenth Annual Tennessee Water Resources (AWRA) Symposium, Montgomery Bell State Park, Tennessee, April 10-12, 2000.

Urbonas, Ben, “Assessment of Stormwater BMPs and Their Technology,” *Water Science Technology*, Vol. 29. No. 1-2, 1994, pp.347-353.

URS Greiner-Woodward Clyde, “Stormwater Inlet Insert Devices Literature Review,” Oakland, CA, April, 1999.

Virginia Department of Conservation and Recreation, *Virginia Stormwater Management Handbook*, First Edition, 1999.

Wagner, C. R., *An Evaluation of the Stormwater Quality Performance of Catch Basin Filter/Inserts*, M.S. Thesis, University of Tennessee, Civil and Environmental Engineering Department, December, 1999.