

**Targeted Constituents**

?? Significant Benefit		?? Partial Benefit		?? Low or Unknown Benefit	
?? Sediment	?? Heavy Metals	?? Floatable Materials	?? Oxygen Demanding Substances		
?? Nutrients	?? Toxic Materials	?? Oil & Grease	?? Bacteria & Viruses	?? Construction Wastes	

**Implementation Requirements**

?? High		?? Medium		?? Low	
?? Capital Costs	?? O & M Costs	?? Maintenance	?? Training		

**Description**

A wet detention basin (also known as a retention pond) is a very desirable method to satisfy both stormwater detention and stormwater quality requirements. It is applicable to most locations for which the contributing drainage area runoff can support a permanent pool of water. Karstic areas prone to sinkhole conditions deserve special attention. A wet detention basin can be enhanced with other stormwater treatment BMPs such as a pretreatment sediment forebay, baffle box, or stormwater quality inlet.

This practice will provide a significant reduction in sediment and most types of pollutants. A wet detention basin, with its permanent pool, is generally more effective than a dry detention basin at allowing sediments and other pollutants to more effectively settle out.

**Selection Criteria**

?? A primary objective is to reduce the incoming peak flow discharge and slow the stormwater runoff response for a particular property or development, thus reducing flooding downstream.

?? Another important objective is to enhance the removal of suspended sediments, trash and debris, oil, grease and other pollutants to protect the water quality of Tennessee streams and channels. Wet detention basins not only enhance physical settling of sediments and pollutants, but will also permit a limited amount of chemical mixing and interaction of dissolved nutrients and metals. Biological uptake will also occur to some degree within a wet detention basin. Dissolved contaminants are removed by a combination of physical adsorption to bottom sediments and suspended fine sediments, natural chemical flocculation, and uptake by aquatic plants.

?? Wet detention basins are ideal for large regional detention facilities; larger drainage areas are likely to have a minimum baseflow entering the system. Wet detention basins should be used if it is imperative to achieve high levels of particulate and dissolved contaminant removal.

?? Wet detention basins also can provide riparian benefits for passive recreation

**Design and Sizing Considerations**

during dry periods (recreational trails, picnicking, birdwatching, wildlife habitat). Portions of a wet detention basin that are not wetted frequently can be attractively landscaped or used for other purposes.

A permanent detention basin design must be stamped by a professional engineer licensed in the state of Tennessee. The professional engineer must be qualified by education and experience to perform the necessary hydrologic and hydraulic calculations. A wet detention basin must be located and designed so that failure of the structure will not result in danger to human life, damage to personal property, inundation of public streets or highways, interruption of public services or utilities, or inconvenience to the general public.

?? As the primary objective, wet detention basins must be designed to have adequate detention storage and outlet structures. Multi-stage detention is required for the 1-year, 2-year, 5-year and 10-year design storm events in all watersheds. Additional stages (i.e. 25-year, 50-year, and 100-year) may be required for special watersheds.

?? The secondary objective, water quality, is obtained through capture of the first flush volume, and also the retention and mixing of stormwater runoff with the permanent pool storage volume. This volume is more likely to contain sediments, particulates from vehicles (such as incomplete combustion, dust from brake linings, tire particles), leaves, trash, cigarette butts, etc. The first flush volume must be captured and then slowly released over a minimum 24-hour period (and a maximum time period of 72 hours). The permanent pool storage volume should be designed with vegetation around the water surface, with riprap or non-erosive materials near inlet and outlet structures. Sediments and particulates continue to settle in the permanent pool storage volume for a few days after a rainfall event.

?? Additional measures may be required to improve stormwater quality, depending upon the nature of the land use and expected pollutants. Pretreatment of stormwater runoff with a media filtration inlet or oil/water separator may be necessary. A trash rack for capturing floating debris is generally considered to be standard equipment for a stormwater treatment BMP. Stormwater runoff that falls onto pavement and rooftops should be detained and treated in a manner that will reduce thermal impacts to streams, such as locating a detention basin away from sunlight by using trees or buildings as shade.

The major features of a retention basin are shown in Figure P-02-1. It is essentially a small pond or lake with rooted wetland vegetation along the perimeter. The storage volume can be divided into two portions: 1) live detention storage, and 2) permanent pool storage.

The live detention storage (above the lowest opening in the outlet structure) provides peak flood control, erosion control and additional treatment benefits. The recommended design includes a sediment forebay (or even multiple forebays) wherever the stormwater runoff enters the wet detention basin. Live detention storage can also include areas which are not frequently inundated; these areas may have multiple recreational uses. The storage volumes necessary to limit peak flow discharges from a wet detention basin to predevelopment peak flows need to be computed. Live detention storage volume is computed using the same methods for both detention basins and retention basins.

The permanent pool storage volume (below the lowest opening in the outlet structure)

provides a quiescent volume for settling of particulate contaminants and the uptake of dissolved contaminants by aquatic plants between storms. Wetland vegetation (in the littoral zone) will improve removal of dissolved contaminants, reduce the formation of algae, stabilize the shoreline and reduce waves, provide dissolved oxygen and habitats for aquatic organisms, and create attractive landscaping. The permanent pool storage volume is computed to determine a minimum residence hydraulic time, which is the average time that a drop of water is expected to remain in the wet detention basin.

### ***Location and Layout***

Basic elements of a retention basin are illustrated in Figures P-02-1 and P-02-2. The recommended design includes the use of a sediment forebay or other stormwater treatment BMPs to reduce sediment and pollutant loading. Principal elements in assessing the potential for a wet detention basin are the existing and proposed site conditions for soils, topography, vegetation, and the amount of available baseflow.

Design flow paths to minimize potential short-circuiting by locating the inlets as far away from the outlet structure as possible. The length-to-width ratio of a basin should be at least 2:1 (and preferably 3:1). If topography or aesthetics require the basin to have an irregular shape, increase the basin area and volume to compensate for dead spaces. Reduce velocity of incoming stormwater with riprap or energy dissipaters.

Bedrock and topography must be considered when grading in some areas of the state. Karst topography may indicate fractured bedrock, dissolved limestone passages, or sinkholes, for which a detention basin would be highly detrimental. The additional water volume that is introduced to the underground limestone passages, or even the additional weight of ponded water, could intensify karst activity and eventually collapse the bed of the pond.

Interaction with site utilities must be considered during preliminary design. Typical utilities include electrical, telephone, cable TV, water, sewer, natural gas, petroleum, etc. These utilities may or may not be in a dedicated utility easement, so it is always necessary to conduct a careful site survey. Detention basins (including embankments) are not allowed over utility lines. Conversely, utility trenches should not be constructed on existing detention basin structures.

Detention basin easements and access must be considered during preliminary design, in order to allow for construction and maintenance. Detention basins that are not frequently inspected and maintained often become more of a nuisance than a beneficial part of a stormwater management program. In particular, provide access for inspection and maintenance to the sediment forebay and to the outlet control structure. It may also be desirable to encourage or discourage public access to the detention basin (by using site grading, signs, fences or gates). Additional safety elements include trash racks, grating over pipes and culverts, gentle side slopes whenever possible, increased visibility and/or lighting in residential areas, etc.

Small detention basins serving individual properties do not offer as much recreational benefits as community or regional detention basins would. Regional facilities can often be landscaped to offer recreational and aesthetic benefits. Jogging and walking trails, picnic areas, ball fields, and canoeing or boating are some of the typical uses. For example, portions of the facility for flood control of major design storms can be used for exercise areas, soccer fields, or football fields. Wildlife benefits can also be provided in the form of islands, buffer areas, or preservation zones.

### *Volume and Size*

The volume of a wet detention basin consists of two elements: the live detention storage (the upper portion of the basin representing detention capability) and the permanent pool storage volume (the lower portion of the basin representing stormwater quality treatment). Detention computations should generally be checked and verified by performing routing computations. The first flush volume must have a minimum size of 4000 cubic feet.

The minimum permanent pool storage volume should have a hydraulic residence time of 14 days, based on average rainfall during the wettest month of the year. In general, a longer hydraulic residence time is desirable as it allows biological and chemical assimilation of nutrients and pollutants to continue for a longer time. In addition, since sediment removal and maintenance of a wet detention basin is very difficult and costly, additional sediment storage should be designed as part of the permanent pool volume.

Since the retention basin contains a permanent pool of water, a continuous baseflow may be required to achieve a constant depth of water.

### *Grading*

The maximum slope above the permanent pool storage volume shall generally be 4:1 (H:V) or flatter. This encourages a strong growth of vegetation on the side slopes and helps to prevent soil erosion. Steep slopes, particularly on embankments or other fill soils, contribute to soil erosion and thereby reduce or negate the effectiveness of a wet detention basin with respect to water quality. Vegetate the side slopes and basin bottom to the maximum extent practical. If side erosion is particularly severe, consider the use of soil stabilization or armoring techniques. Detention basins should not be located immediately above or below a steep slope or grade, because impounded water may create slope stability problems.

The littoral zone is an area of the detention basin which supports rooted wetland vegetation. The littoral zone should be 1 to 2 feet below the normal water level, with a gentle slope of 6:1 (H:V) or flatter. Typically the littoral zone is 10 feet wide. The remainder of the permanent pool storage volume may have slopes as steep as 2:1 (H:V); this portion of the wet detention basin is generally protected against rainfall, water velocities and wave action so that erosion does not occur.

The minimum width for top of embankment is 5 feet. The embankment height should allow for up to 10% settlement of embankment, unless the embankment is thoroughly compacted with vibratory equipment or sheepsfoot rollers. The top of embankment (after expected settlement) shall generally be at least 2 feet above the top of outlet structure and at least 1 foot above the peak 100-year water surface elevation. Compaction in the immediate area of the emergency spillway can be difficult, but is necessary.

Retaining walls may be used on one or more sides of a detention basin if properly designed. Analysis of a retaining wall should include effects of saturated soil behind the retaining wall, in addition to the usual design considerations of vehicle and structural loadings above the retaining wall. In general, concrete retaining walls should not face southward in order to reduce the potential for heating on hot summer days. Using a backslope drain (see Figure P-01-5 for a detail) can increase the flow

path lengths to prevent short circuiting of the detention basin.

### ***Outlet Structure***

Detention basin outlet structures should be constructed from durable materials such as concrete or masonry block. Corrugated metal pipe (CMP) and HDPE (plastic) risers and drain pipes are popular in engineering design, but are susceptible to crushing and flotation for detention basins. A concrete outlet structure is generally preferable to a masonry block structure because it is sturdier and more durable. Provisions should be made for sufficient reinforcement and anchoring.

The specific flow-controlling elements of an outlet structure may include one or more of the following: a circular orifice, a noncircular orifice, a rectangular weir, a trapezoidal weir, a triangular weir, a V-notch weir, culvert entrance control or a riser overflow opening. The V-notch weir is an efficient combination of low maintenance requirements and a wide range of flow discharges.

Figures P-02-3 and P-02-4 illustrate possible designs for the outlet structure. These details are only two possible ways to accomplish stormwater detention and stormwater quality control. The first flush volume is typically drained during a minimum time of 24 hours by using an orifice or orifices with a designed size. Maximum drain time should be less than 72 hours to allow for sufficient volume recovery prior to the next period of rainfall. Figure P-02-5 shows an alternative outlet structure with a water quality manhole.

### ***Emergency Spillway***

An emergency spillway should be included in addition to the primary outlet structure on a retention pond. The purpose of this spillway is to pass storm events that exceed the design capacity of the pond, in order to prevent overtopping the embankment. The emergency spillway capacity should be designed to prevent overtopping of the embankment structure or dam during a storm event commensurate with the impoundment volume, dam size, and downstream flood hazard potential in event of dam failure. The minimum spillway capacity should be capable of handling a 100-year storm event. The designer is referenced to the requirements set forth in the Tennessee Safe Dams Act and Regulations.

### ***Other Design Elements***

- ? ? Sediment forebay – to facilitate the cleanout of sediment, trash, debris, leaves, etc. The sediment forebay typically contains 5% to 10% of the total volume for a wet detention basin. It should be located at a point where velocities have dissipated, to allow large sediments and debris to settle out. A forebay can be separated from the remainder of a detention basin by several means: a lateral sill with rooted wetland vegetation, rock-filled gabion, rock retaining wall, or rock check dam placed laterally across the basin. The sediment forebay should be easily accessible so that it can be inspected and maintained.
- ? ? Public safety should be considered, particularly in residential areas. Operating detention basins often attract neighborhood children. Avoid steep slopes and dropoffs; consider routes for escaping the detention basin if a person had accidentally fallen in. Provide fencing and signs in areas where children may

potentially play, or in areas which have deeper water. Limit access to the outlet structure.

- ? ? Mosquitoes can be reduced by installing a steeper shelf transition at the water surface to reduce areas with water depths less than 12 inches. Small rock walls, gabions or other structures may help to create this shelf transition. Habitats for the introduction of gambusia (mosquito fish) are also beneficial if the design also includes maintaining water levels for fish survival during the dry season. Water levels also need to be maintained during winter months for fish to survive the cold weather.
- ? ? Antiseep collars (around the outlet pipe) and cutoff clay layers (within the embankment) are usually necessary to prevent internal piping and erosion. An antiseep collar should extend at least one pipe diameter from culvert in all directions, with compacted clay backfill using small mechanical tampers.
- ? ? To prevent the outlet riser from clogging, include trash racks or other debris barriers with a maximum opening size of 2" (and preferably 1") on all outlet structures, except for any emergency spillway structures that are designed for a 25-year storm or greater return period. Trash racks that are placed at an angle to the direction of flow are somewhat less vulnerable to clogging.
- ? ? Provide means for vehicle access to the wet detention basin. Detention basins must be located in a maintenance easement so that authorities have the right to inspect the facility. Maintenance easements that are not adjacent to a municipality's right-of-way must also have an access easement, which allows for maintenance vehicle access without large trees or excessive vehicle grades.
- ? ? Include a skimmer, oil/water separator or other type of stormwater runoff pretreatment for detention basins with greater than 50 percent impervious surface or a potential for oil and grease contamination (such as vehicle fueling and maintenance facilities, in addition to large parking areas).
- ? ? An antivortex device for the outlet structure may be potentially needed for very large detention basins in areas where public access is not controlled. The antivortex device may be a combination of vanes above the outlet structure or guide walls around the outlet structure, that might increase the inlet flow efficiency, lessen the chance of humans drowning or reduce the potential for erosion and structural undercutting.
- ? ? Provide rooted vegetation at the pond perimeter, which serves several functions. Rooted vegetation enhances the removal of dissolved pollutants and reduces the formation of floating algae. It provides some habitat for insects, aquatic life, and wetland wildlife. The littoral zone for rooted vegetation should be about 10 feet wide with a water depth of 1 to 2 feet. Vegetation in general slows flow velocities and increases settling. However, large trees should be prevented from growing on the pond, especially on the embankment.
- ? ? If placement of wetland vegetation along the perimeter is not feasible, consider the use of non-rooted wetland species (i.e. floating plants). Non-rooted vegetation is actually more effective than rooted vegetation in removing dissolved nutrients and metals. Non-rooted vegetation can be placed within floating containers to facilitate periodic removal and cleaning. Another alternative is a rock filter or bed to

support non-rooted vegetation (similar to design of wastewater oxidation ponds).

**Construction/  
Inspection  
Considerations**

Make sure the outlet is installed as designed. Special attention should be given to the elevations of each outlet geometry change, shape of the various weirs or orifices, and installation of cut-off collars in embankments.

**Maintenance**

Effective and safe operation of a detention basin depends on continuous maintenance of all system components. This means that the owner should have a regular inspection program in place for checking the condition and integrity of the basin, dam, and outlet control system to prevent minor problems from becoming serious safety and operation problems. Detention basin easements and access must be considered during the planning stage in order to allow for proper inspection and maintenance.

?? Inspect the wet detention basin regularly (several times a year) and particularly after heavy rainfall events. Record all observations and measurements taken. Perform any maintenance and repairs promptly. Remove debris and trash after storm events. Check outlet structure regularly for clogging.

?? Remove sediment from forebay regularly to prevent resuspension or movement. The wet detention basin should be dredged or excavated when 10% of permanent pool storage volume has been lost. Sediment removal in a wet detention basin is a major effort requiring dewatering, difficult equipment access, wet soils, and some loss of wildlife and vegetation. Sediment may be permitted to accumulate if the detention basin volume has been oversized with adequate controls.

?? Maintain a thick and healthy stand of vegetation. Mow or trim at regular intervals to encourage thick growth. Remove leaves, grass clippings, or sticks from the wet detention basin to prevent stormwater pollution. Remove trees or nuisance vegetation as necessary in order to protect embankments. Repair banks and eroded areas.

?? Reduce mosquitoes as necessary. Trim vegetation or alter water surface perimeter to reduce ponded depths that are less than 12 inches. Design of the wet detention basin may include a steeper depth transition to reduce shallow water depths less than 12 inches. Gambusia (mosquito fish) can also be placed in larger ponds if water levels are maintained to insure their survival during the dry season.

?? A fountain may be desirable to increase the amount of dissolved oxygen in the water. Depths greater than 12 feet may develop anaerobic conditions which is not desirable.

?? If both the operational and aesthetic characteristics of a wet detention basin are not properly maintained, recognize that it will become an eyesore and a negative environmental impact. Vegetation needs to be trimmed or harvested. Ensure that repairs are made to walkways, picnic tables, signs and public recreation equipment as needed.

?? Signs should be posted at detention ponds to discourage local homeowners from depositing yard trimmings, waste, and fill materials inside the basin.

***Sediment Removal***

A primary function of stormwater treatment BMPs is to collect and remove sediments. The sediment accumulation rate is dependent on a number of factors including watershed size, facility sizing, construction upstream, nearby industrial or commercial activities, etc. Sediments should be identified before sediment removal and disposal is performed. Special attention or sampling should be given to sediments accumulated from industrial or manufacturing facilities, heavy commercial sites, fueling centers or automotive maintenance areas, parking areas, or other areas where pollutants are suspected. Sediment should be treated as potentially hazardous soil until proven otherwise.

Some sediment may contain contaminants for which TDEC requires special disposal procedures. Consult TDEC – Division of Water Pollution Control if there is any uncertainty about what the sediment contains or if it is known to contain contaminants. Clean sediment may be used as fill material, hole filling, or land spreading. It is important that this material not be placed in a way that will promote or allow resuspension in stormwater runoff. Some demolition or sanitary landfill operators will allow the sediment to be disposed at their facility for use as cover. This generally requires that the sediment be tested to ensure that it contains no hazardous or toxic substances.

**Cost Considerations**

Generally more expensive than dry ponds and biofilters.

**Limitations**

- ?? A retention basin will require frequent inspection and maintenance. Trash, debris, leaves and other large items should be removed from the detention basin following each rainfall event. If upstream erosion is not properly controlled, wet detention basins can be maintenance-intensive with respect to sediment removal, nuisance odors, insects and mosquitoes, etc. Municipalities should develop clear policies on who is responsible for maintaining detention basins.
- ?? Controlling mosquitoes and oxygen levels in retention ponds is a concern.
- ?? A retention basin may not have sufficient vegetation on the slopes and bottom to prevent erosion and pollutant resuspension. Vegetation must be maintained and cut at adequate intervals.
- ?? A retention basin that impounds more than 30 acre-feet of volume (and minimum 6 feet high) or which is higher than 20 feet (and minimum 15 acre-feet of volume) is subject to the Tennessee Safe Dams Act of 1973 and as amended by law. The Safe Dams Act is administered by the TDEC Division of Water Supply; further information on design standards, regulations and permit applications is available at the TDEC website:  
<http://www.state.tn.us/environment/permits/safedam.htm>
- ?? Retention basins may not be feasible in very dense urban areas. Do not locate detention basins on steep unstable slopes or on shallow fractured bedrock. Impervious soils such as clay are desirable to maintain water levels during the summer or other dry periods.

**Additional  
Information**

- ?? Retention ponds are of interest where the removal of the dissolved constituent fraction is of concern, particularly nutrients and metals. Dissolved contaminants are removed by a combination of processes: physical adsorption to bottom sediments and suspended fine sediments, natural chemical flocculation, and uptake by aquatic plants.
- ?? Rooted vegetation around the pond perimeter serves several functions. It enhances the removal of dissolved pollutants; it may reduce the formation of floating algal mats; it reduces the risk of people falling into deeper areas of the pond; it limits erosion into the pond; and, it provides some habitat for insects, aquatic life, and wetland wildlife.
- ?? Vegetation near the exit will assist settling of solids. An alternative is a rock filter which is used in many wastewater oxidation ponds where loss of algae in the effluent is a common problem during the growth season.
- ?? If placement of wetland vegetation along the perimeter is not feasible, consider the use of devices that retain non-rooted wetland species. Non-rooted vegetation is more effective than rooted vegetation in removing dissolved nutrients and metals. The vegetation grows within the device, which is periodically removed and cleaned, thereby removing the contaminants from the facility.

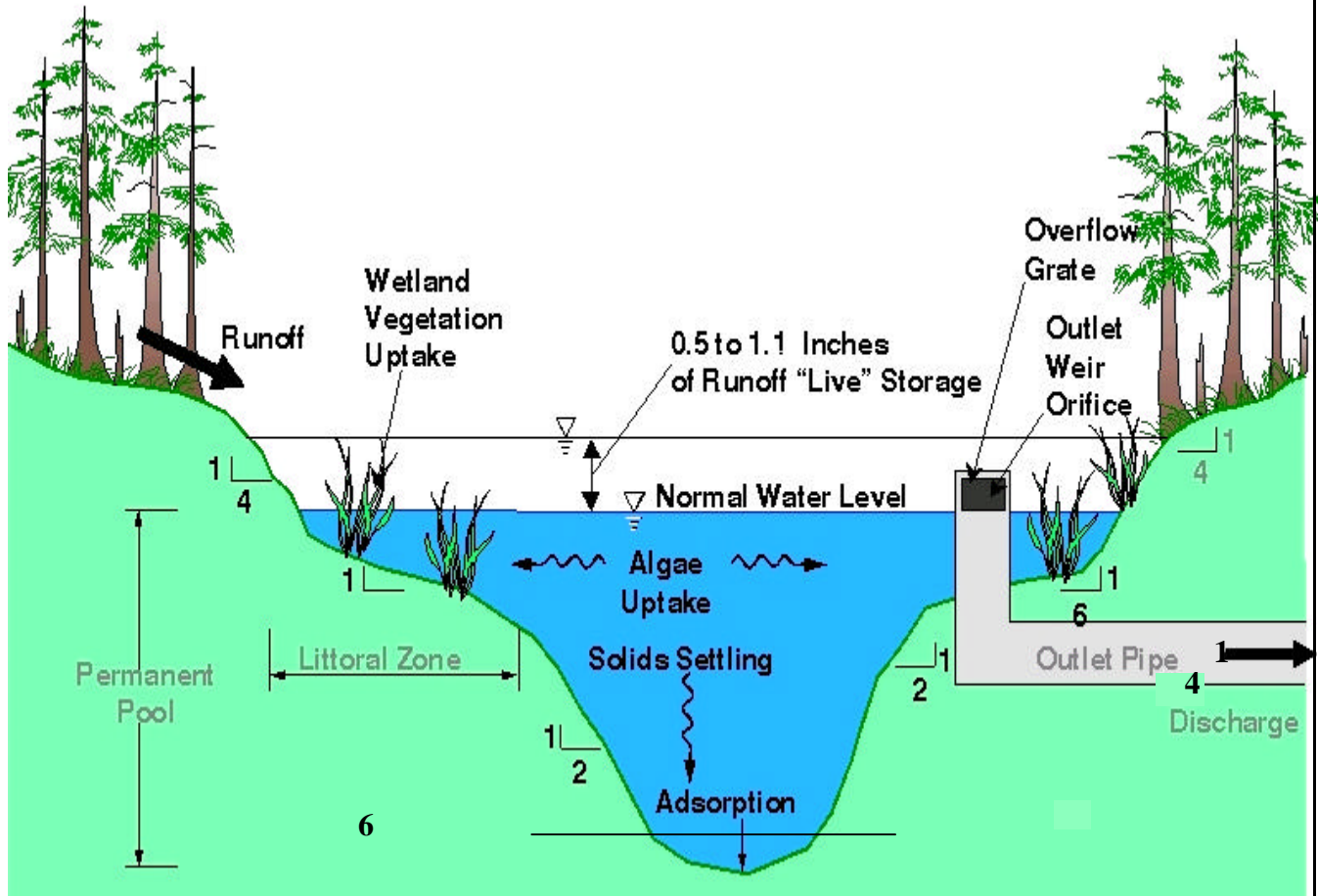

**Figure P-02-1**  
**Schematic of Wet Detention Basin**

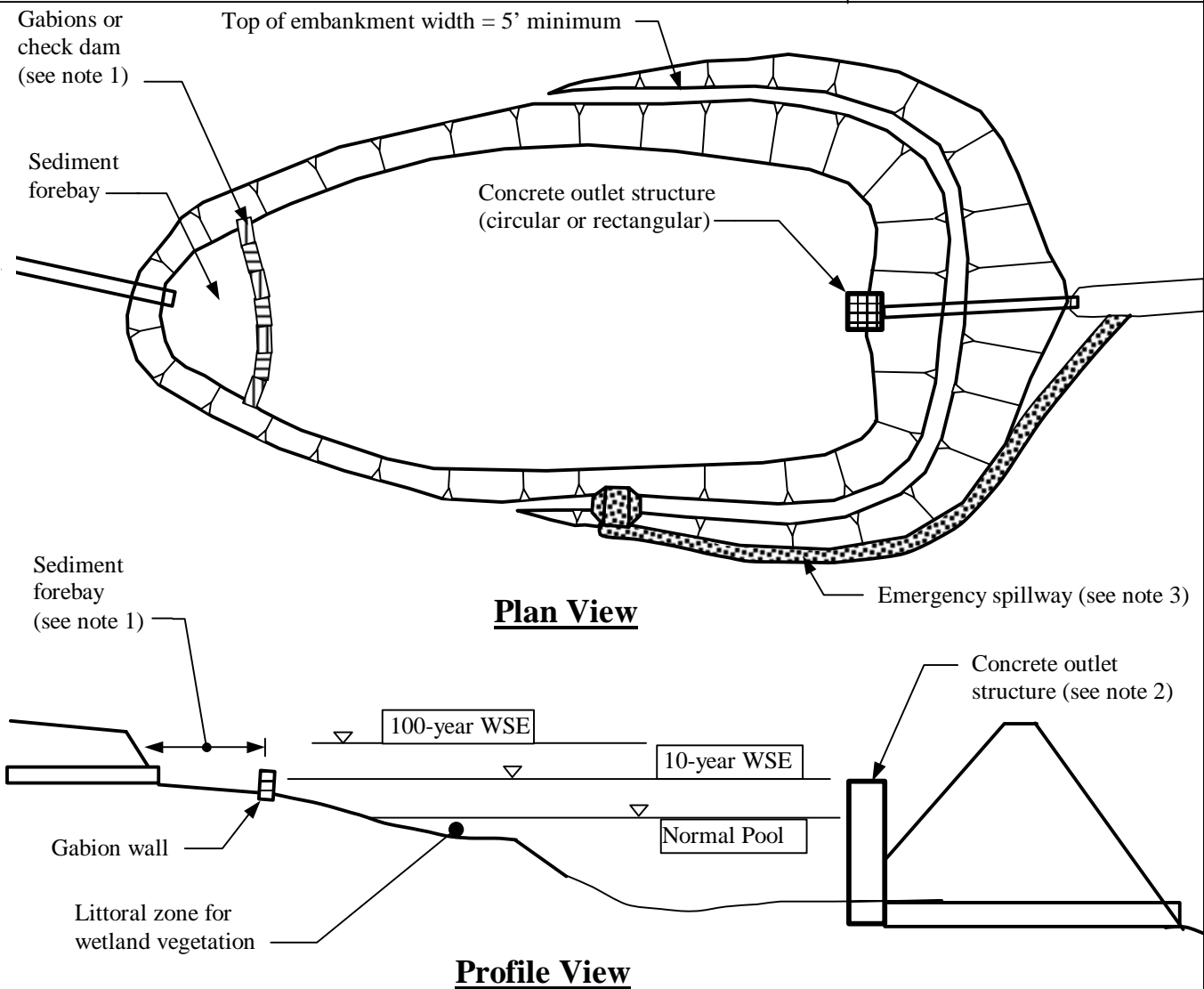

**Plan View**

**Profile View**

NOT TO SCALE

**Notes:**

1. A sediment forebay can be constructed from gabions, rock check dams, or a separate berm with culvert. A sediment forebay can facilitate the capture and cleanup of coarse sediments, debris and trash.
2. The outlet structure typically has orifices or weirs at computed elevations that will release the 1-year, 2-year, 5-year and 10-year storms at the specified predevelopment peak flow rates.
3. The emergency spillway is generally constructed on natural ground or excavated areas (rather than fill soils) to reduce the potential for erosion and washout.

**Figure P-02-2  
Typical Wet Detention Basin Layout**

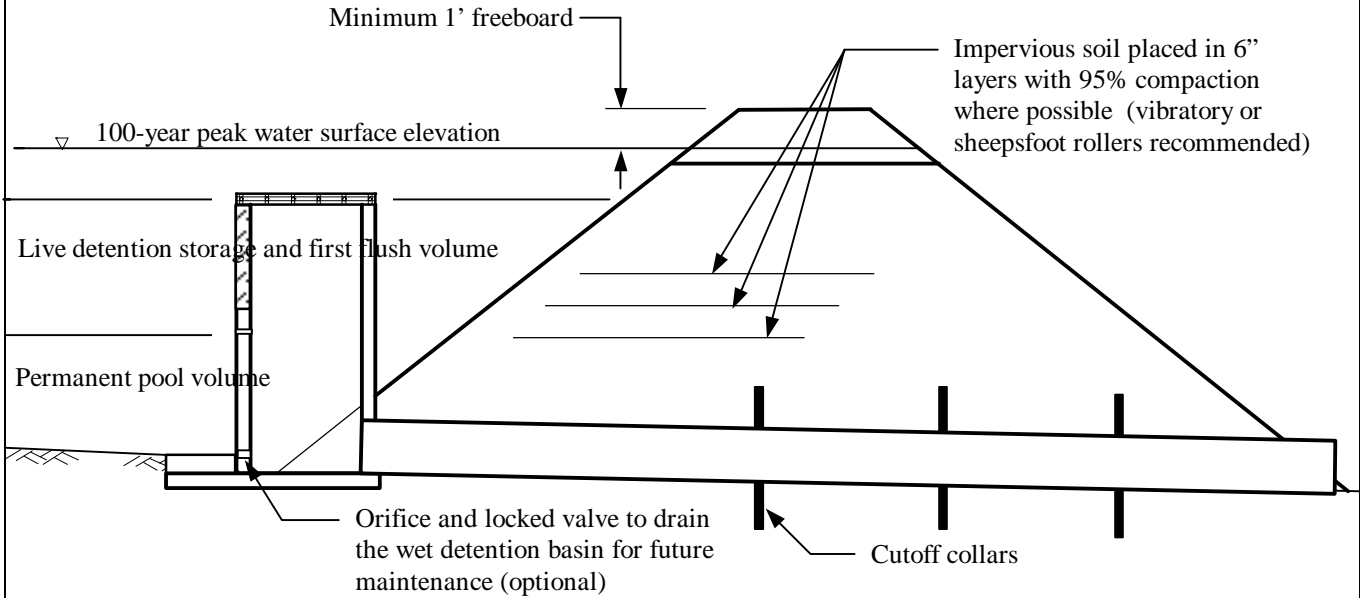

**Typical Outlet Structure (V-notch)**

NOT TO SCALE

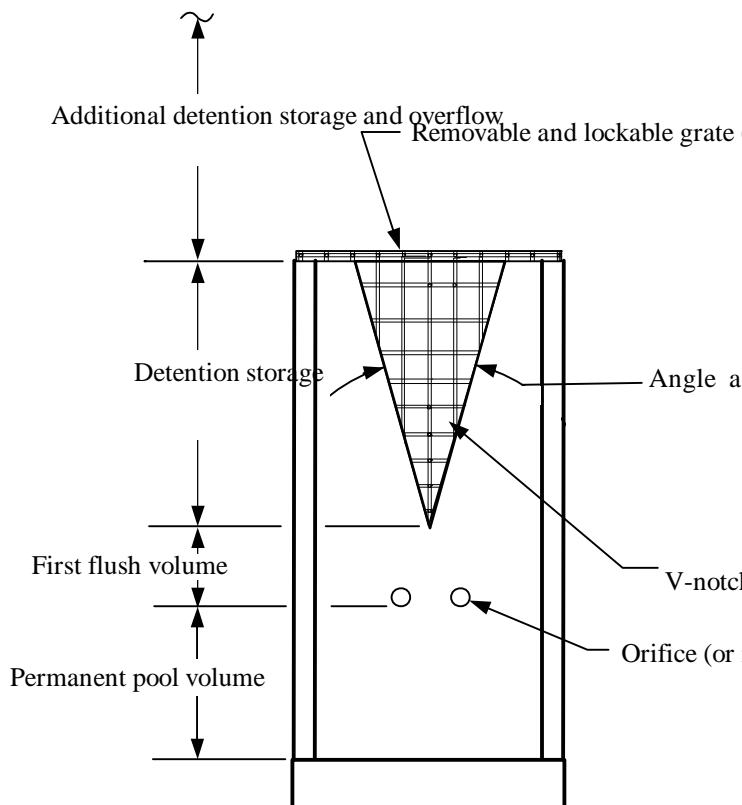

**Notes:**

1. This example of a typical outlet structure shows a V-notch weir which should be sized to release the 1-year, 2-year, 5-year and 10-year storm peak flows at the predevelopment rates.
2. The first flush volume orifice or orifices are sized to release the first flush volume over a period of 24 hours. Protect the orifice from clogging with a trash rack.

**Figure P-02-3**  
**Typical Outlet Structure**

(shown with a V-notch weir & sand filtration box)

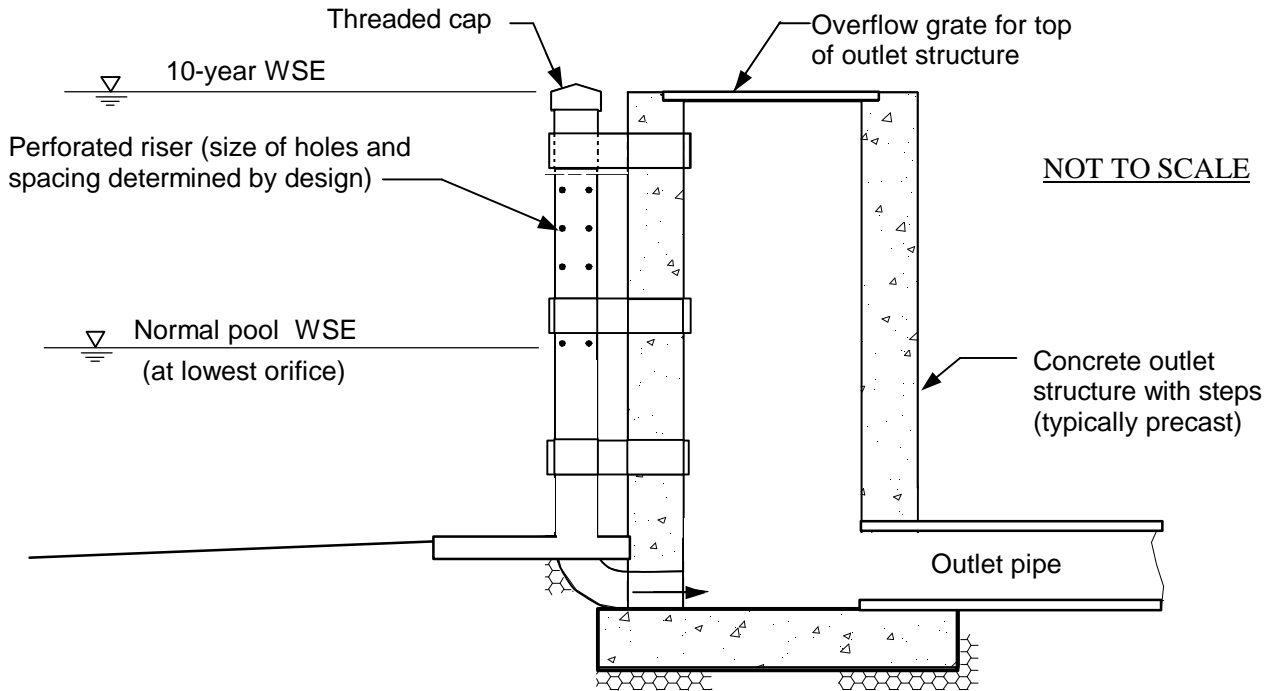

**Note:**

This type of outlet structure may be used if there is adequate protection and structural support for the perforated riser.

**Figure P-02-4**  
**Outlet Structure – Alternative A**

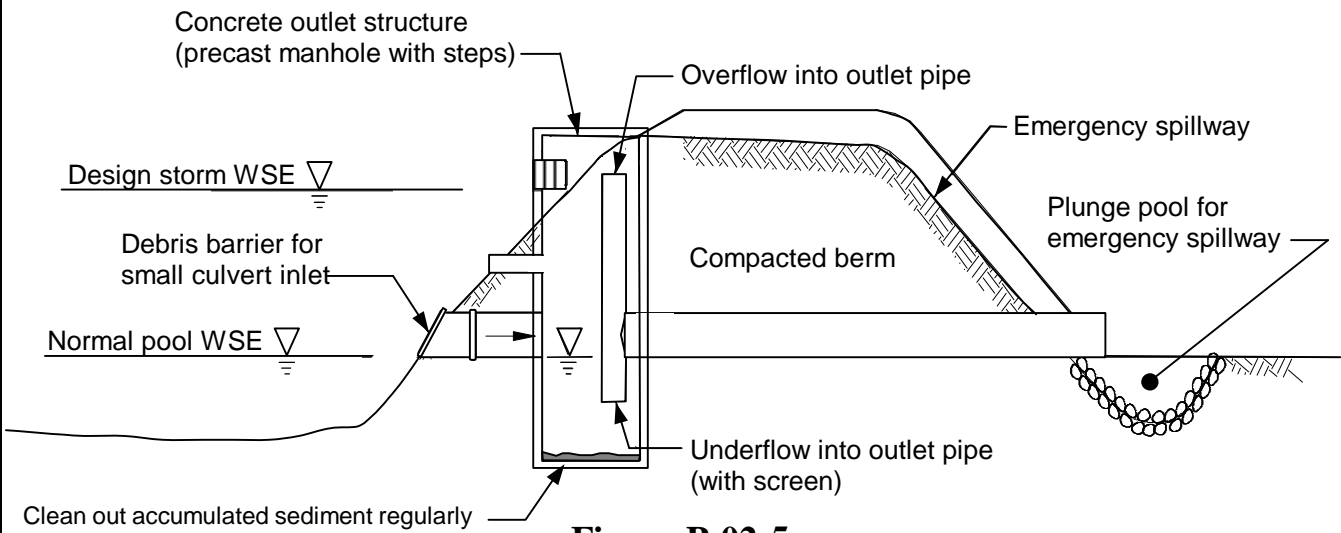

**Figure P-02-5**  
**Outlet Structure – Alternative B**  
(includes water quality manhole with underflow)

**References**

Camp Dresser & McKee, *Sevenmile Creek Basin Pilot Stormwater Quality Master Plan*, Report to Metropolitan Nashville and Davidson County, Tennessee, February 2000.

Camp Dresser & McKee, Larry Walker Associates, Uribe & Associates, Resources Planning Associates, *Industrial/Commercial Handbook, California Storm Water Best Management Practice Handbooks*, for the California Storm Water Quality Task Force (SWQTF), March 1993.

Camp Dresser & McKee, Larry Walker Associates, Uribe & Associates, Resources Planning Associates, *Municipal Handbook, California Storm Water Best Management Practice Handbooks*, for the California Storm Water Quality Task Force (SWQTF), March 1993.

Camp Dresser & McKee, Woodward-Clyde, Aguilar Engineering, Psomas & Associates, MK Centennial, *Construction Contractors Guide and Specifications, Caltrans Storm Water Quality Handbooks*, prepared for the California Department of Transportation, 1997.

Charlotte (city), Mecklenburg County, Debo and Associates, Ogden Environmental and Engineering Services, *Charlotte Mecklenburg Storm Water Design Manual*, July 1993.

Debo, Thomas, and Andrew Reese, *Municipal Storm Water Management*, Lewis Publishers, 1995.

Dewberry and Davis Inc., *Investigation of Potential Sediment Toxicity from BMP Ponds*, Northern Virginia Planning District Commission, 1990.

Florida Department of Environmental Regulation, *The Florida Development Manual: A Guide to Sound Land and Water Management*, June 1988.

Florida Department of Transportation, *Maintenance Guidelines for Accumulated Sediments in Retention/Detention Ponds Receiving Highway Runoff*, 1991.

Kleinschmidt, S.R., *Hydraulic Design of Detention Tanks*, Journal of Boston Society of Civil Engineers, Volume 48 (4), page 247, 1961.

Limnion Corporation, “*Nutrient Removal Using a Submersed Macrophyte System*”, and “*Metals Removal Using a Submersed Macrophyte System*”.

Maine Department of Environmental Protection, *Stormwater Management for Maine: Best Management Practices*, November 1995.

Maryland Water Resources Administration, *Feasibility and Design of Wet Ponds to Achieve Water Quality Control*, 1986.

McCormick, C.D., F.M. Schmidt, and C. Hasty, *Retrofitting Existing Dry Ponds to Benefit Stormwater Quality*, Tennessee Society of Professional Engineers (TSPE) Professional Development Seminar, March 1999.

Merritt, F.S., M.K. Loftin, and T.J. Ricketts, *Standard Handbook for Civil Engineers*, Fourth Edition, McGraw-Hill, 1996.

Metropolitan Washington Council of Governments (MWCOG), *A Current Assessment of Urban Best Management Practices: Techniques for Reducing Nonpoint Source Pollution in the Coastal Zone*, Publication #92705, March 1992.

Rast, W., R.A. Jones, G.F. Lee, *Predictive Capability of U.S. OECD Phosphorus Loading - Eutrophication Response Models*, Journal of Water Pollution Control Federation, Volume 55, Number 7, pages 990-1003, July 1978.

Rich, L., *A Critical Look at Rock Filters*, Journal of Environmental Engineering., ASCE, Volume 114, page 219, 1988.

Roesner, L.A., J. Aldrich, J. Hartigan, et.al., *Urban Runoff Quality Management – WEF Manual of Practice No. 23 / ASCE Manual and Report on Engineering Practice No. 87*, 1998.

Shepp, D., D. Cole, and F. Galli, *A Field Survey of the Performance of Oil/Grit Separators*, Metropolitan Washington Council of Governments (MWCOG), 1992.

Tennessee Safe Dams Act of 1973, TCA, Section 69-12-101, as amended. 1991.

United States Environmental Protection Agency (USEPA), *Methodology for Analysis of Detention Basins for Control of Urban Runoff Quality*, EPA 440/5-87-001, 1986.

United States Department of Agriculture (USDA), Soil Conservation Service (SCS), *Urban Hydrology for Small Watersheds*, Technical Release 55 (TR-55), June 1986.

Urban Drainage & Flood Control District, Denver Colorado, *Urban Storm Drainage Criteria Manual: Volume 3 – Best Management Practices - Stormwater Quality*, September 1999.

Virginia Department of Conservation and Recreation, *Virginia Stormwater Management Handbook*, First Edition, 1999.

Walker, W., *Phosphorus Removal by Urban Runoff Detention Basins*, Lake and Reservoir Management, North American Society for Lake Management, Volume III, pages 314-326, 1987.

Wanielista, M., *Final Report on Efficiency Optimization of Wet Detention Ponds for Urban Stormwater Management*, University of Central Florida, 1989.

Zirschky, J., and S. Reed, *The Use of Duckweed for Wastewater Treatment*, Journal of Water Pollution Control Federation, Volume 60, Number 7, pages 1253-1258, July 1988.